



P R O D U C T M A N U A L

INLINE 3000C
FOOD CABINETS



Refrigerated Cabinets

Curved Format

INSTALLATION - OPERATION - MAINTENANCE



**Copyright © August 2018, Future Products Group Limited.
All rights reserved.**

No part of this publication may be reproduced, stored in a retrieval system, or transmitted in any form or by any means, electronic, mechanical, photocopying, recording or otherwise, without the prior written permission of Future Products Group Ltd.

Table of Contents

INTRODUCTION	7
Welcome	7
Future Products Group (FPG)	7
Guidance and Help	7
Warranty	7
Warranty Period	7
Liability Exceptions	8
Specific Exclusions	8
Assessment	8
Time Limit	8
Caution	8
OPERATION	9
Cabinet Layout	9
3000 Series Cabinets	9
Lighting	9
Condenser Unit	9
Controls	10
Control Panel	10
Power and Refrigeration	10
Lights	10
Temperature Controller	10
Temperature Controller Adjustment	10
Preparation	11
Shelf Location and Ticketing	11
Shelf Adjustment	11
Power Supply and Fans	11
Turn on Refrigeration	11
Fumes and Odours	11
Defrost Cycle	12
Load Cabinet	12
Loading Restrictions	12
Close all Doors	12
Turn on Lights	12
Routines	13
After Hours	13
Cleaning	13
De-frost Cycle	13
Door Opening	13
TROUBLE SHOOTING	14



CLEANING	15
Cautions	15
Power	15
Water	15
Exterior	15
Metal Surfaces.....	15
Glass	15
Sliding Doors	15
Louvers.....	16
Interior.....	16
Access to the Cabinet Base Cavity	16
Cleaning the Base Cavity	17
Cooling Fins.....	17
Temperature Probes.....	17
Condensate Container	17
Trays, Shelves & Air Grills.....	17
Re-assembly.....	17
Routines	18
Schedules	18
Warning	18
Condenser Assembly	18
Condensate	18
Inspection	18
Fault Correction	18
INSTALLATION	19
Regulations	19
Compliance with Local Requirements	19
Setting Up.....	19
Unpacking.....	19
Site Preparation.....	19
Cabinet Preparation.....	19
Shelf Trays	19
Grounding.....	20
Power Supply	20
Isolation	20
Location.....	21
Ventilation.....	21
Air Flow Requirements	21
Air Duct.....	21
Access	21
Condenser Unit, remote installation.....	22
Refrigerant Connections (Refrigeration Engineer)	22
Temperature Probe (Electrician)	22
Power Connections (Electrician)	22
Livery	23
Custom Inserts	23

SERVICING	24
Control Gear	24
Location	24
Lighting.....	24
Caution	24
Test Lighting Components	24
Access to LED Strips.....	24
LED Strip Replacement.....	24
Refrigeration	25
Caution	25
Condenser Assembly	25
Ventilation Panels.....	25
Cabinet Air Circulation Fan	25
Temperature Regulator XR40CX	26
XR40CX Compressor Control	26
XR40CX Defrost Control	26
XR40CX Key Functions.....	27
XR40CX LED Functions.....	27
FPG Settings	30
Dixell Default Settings	30
XR40CX Hot Key.....	31
XR40CX Alarm Signals	32
XR40CX Connections	32
Door Seals	33
Seal Replacement	33
Sliding Doors	33
Mains Lead	33
Lead Replacement	33
 SPECIFICATIONS.....	 34
Mechanical	34
Electrical	34
Controller Settings	35
Dixell XR40CX Settings.....	35
Compliance	36
Safety Aspects.....	36
Operational Safety.....	36
Performance Aspects of Refrigerated Cabinets	36
Equipment Disposal	36
Specialist Disposal	36
Hazardous Substances	36
Improvements	36
Ongoing Development.....	36



ELECTRICAL CIRCUIT DIAGRAMS	37
Model: IN 3C08.....	37
Model: IN 3C12.....	37
Model: IN 3C15.....	38
Model: IN 3C18.....	38
SPARE PARTS	39
Cabinet Serial Number	39
MECHANICAL DRAWINGS	41
Dimensions	41
IN-3C08/12/15/18	41
Cabinet Variants	42
Livery	42
Bench Cut-outs	42
In Bench Mounting.....	42
On Bench Mounting.....	43
On Bench Mounting with Integral Condenser	43
Ventilation	44
Under-bench Enclosure.....	44
Air Flow Baffles.....	44
Grill Dimensions	44

INTRODUCTION

Welcome

REFRIGERATED CABINETS - INTRODUCTION

Future Products Group (FPG)

Welcome to the world of FPG! Our products are designed and engineered to give you the optimal performance that you deserve with innovative visual merchandising appeal.

We are confident that you will be delighted with your state of the art inline food service cabinet, and that it will become a valued appliance in your store.

Guidance and Help

Any new appliance can seem very complex and confusing at first glance. To ensure you receive the utmost benefit from your new inline cabinet, there are two things you can do.

- Before operating the cabinet, please read the instruction book carefully and follow its recommendations. The time taken will be well spent. These instructions both general and technical tell you how to install, operate and look after your inline food service cabinet so that you can receive the full benefits that this cabinet has to offer.
 - These instructions cannot, however, cover all eventualities. If you are unsure of any aspect of the installation, instructions or performance of your cabinet, contact your dealer promptly or contact us via email to support@fpgworld.com.
-

Warranty

REFRIGERATED CABINETS - INTRODUCTION

Warranty Period

Future Products Group Limited warrants, to the original purchaser of an FPG manufactured food service cabinet that for ONE YEAR (12 months), from the date of purchase, any defect in workmanship or material resulting in the product malfunctioning while under correct use will be rectified.

The warranty is extended to THREE YEARS (36 months), for refrigeration condenser units. Conditions apply, see Liability Exceptions.

Liability under this warranty is limited to replacing or repairing a part, without charge.

Continued on next page



Warranty cont.

REFRIGERATED CABINETS - INTRODUCTION

Liability Exceptions

Liability under this warranty does not include:

- Any loss, or damage or expenses directly or indirectly arising from use or inability to use the product or from any other cause.
 - Any part of the cabinet which has been subject to misuse, neglect, alteration, incorrect installation, accident, or damage caused by transportation, use of abrasive or caustic chemicals, flooding, fire or acts of God.
 - Damage, resulting from failure to have the cabinet regularly serviced every three months by a refrigeration engineer. NB: You will be required to provide copies of service records in the event of compressor failure.
 - Any damage or malfunction resulting from the use of non-FPG supplied spare parts.
-

Specific Exclusions

The following are specifically excluded from warranty:

- Breakage of glass or plastic components, or the replacement of LED lighting assemblies or gaskets.
 - Maladjustment of the electronic refrigeration controller, by an unqualified person.
 - Routine compressor / radiator cleaning.
 - Failure to re-assemble the cabinet correctly after cleaning.
 - Fair wear and tear.
-

Assessment

The liability under this warranty is dependent on an assessment by FPG, to determine the defect in workmanship or materials.

Time Limit

FPG does not guarantee that any service to be performed under this warranty will be carried out within any particular time limit.

Caution

No warranty claim will be accepted unless authorised by FPG prior to commencement of service.

OPERATION

Cabinet Layout

REFRIGERATED CABINETS - OPERATION

3000 Series Cabinets

The 3000 Series cabinets are available with either fixed glass or sliding glass front doors, and sliding glass rear doors.

The series includes Ambient, Heated and Refrigerated models.

The cabinets are designed for bench mounting, and in the case of the refrigerated cabinets, the condenser unit can be supplied separately, for mounting either under the bench or remotely.

Condensate must be piped to a drain or removable container.



Lighting

All cabinets are fitted with high efficiency LED lighting strips in the ceiling of the cabinet as standard.

Additional LED strips, below each shelf, are available as an optional extra, at the time of ordering.

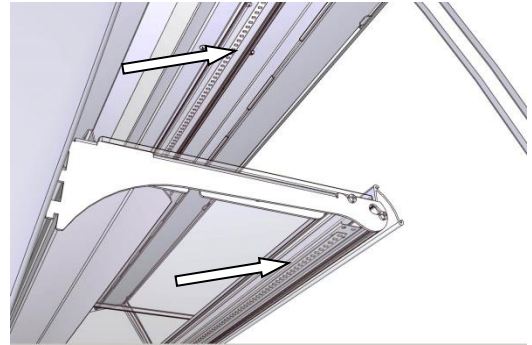

Condenser Unit

If mounted below the bench, ventilation louvres must be provided to ensure adequate air flow for efficient operation of the refrigeration condenser.

See: - **Installation**-Location



Controls

REFRIGERATED CABINETS - OPERATION

Control Panel



The controls are mounted on the back of the cabinet.
There is a power switch, a light switch and a refrigeration control panel.

Power and Refrigeration



To turn the power and refrigeration on, rotate the switch, with the ON/OFF symbol. The refrigeration will be ON by default, see below.

Lights



To turn the lights on, rotate the switch, with the LIGHT symbol.

Temperature Controller



The controller regulates the cabinet temperature and controls the automatic defrost cycles.

The display indicates the cabinet air temperature.

Temperature Controller Adjustment

Caution:
This controller should only be adjusted by a qualified service technician.

The controller is set up during manufacture of the cabinet, and should not require further adjustment.

The indicated temperature is sensed by a probe in the return air, entering the cooling coil. This is used to control the refrigeration condenser operation, and will be marginally higher than the internal cabinet temperature.

Incorrect adjustment can cause the fins to ice up, resulting in reduced airflow and poor performance.

The temperature of the condenser is also monitored, to protect the compressor from damage resulting from blocked radiators etc.

The controller also governs the de-frost cycles, and incorrect adjustment can again lead to poor temperature control or possible overflow of condensate.

If you think an adjustment may be needed, call the service technician.

Preparation

REFRIGERATED CABINETS - OPERATION

Shelf Location and Ticketing



All shelves are adjustable in height and can easily be moved up or down, to match product size.

If shelf lights are fitted, the movement is restricted to 50mm, because of the electric cables to the lights. For greater movement contact the manufacturer or supplier for advice, as electrical modifications may be required.

The front and rear edges of the shelves are profiled to carry ticketing/labels.

Shelf Adjustment

To move the shelf brackets, first remove the sliding doors and the shelf trays.

Using two people, one on each bracket, lift the brackets straight up firmly and then pull the brackets forward, to disengage them from the slots in the support posts.

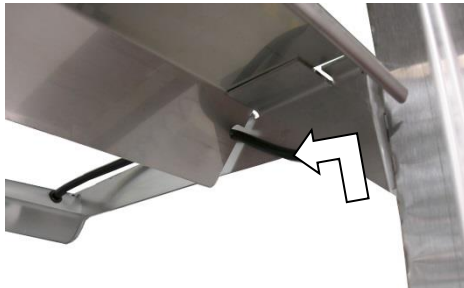

Insert the brackets into their new position, and push bracket down firmly.

The brackets may be positioned to give two different degrees of slope to the shelves.

Refit all shelf trays and doors.

N.B. Make sure brackets are pushed down as far as they can go. Failure to do this may result in shelf collapse, when loaded with product.

Power Supply and Fans

Ensure that power is connected to the cabinet.

Note that the evaporator and condenser fans will run whenever the main switch is turned on.

Turn on Refrigeration

The refrigeration condenser will run as soon as the cabinet main switch is turned ON, and the cabinet temperature will begin to fall.

The temperature controller is pre-set to maintain the cabinet temperature to 2° - 4° C, and should not need adjustment.

Fumes and Odours

Before use, operate the cabinet for 1-2 hours to remove any fumes or odours, which may be present. This will avoid possible tainting of food.

Continued on next page

Preparation cont.

REFRIGERATED CABINETS - OPERATION

Defrost Cycle

Note that the defrost times are set from when the cabinet is first turned on. If they are required at a particular time, you must turn on the cabinet four hours before the first defrost required. The cycles will then occur every four hours, provided that the cabinet is not switched off.

Each defrost cycle terminates as soon as the temperature of the evaporator fins rises to a level indicating that all ice has melted.

This active defrost system improves the energy efficiency of the cabinet, and minimises temperature fluctuations.

Load Cabinet

Load the cabinet with pre-chilled product, from either the front or rear doors.

The cabinet is designed to maintain the temperature of pre-chilled product at between 2° and 4°C. It is not a refrigerator, and consequently, if warm product is introduced, there could be some delay before the operating temperature falls to the normal operating level.

Loading Restrictions

It is important to leave adequate free space for the refrigerated air to circulate within the cabinet.

Product should be kept clear of the lightened areas, shown in the picture.

A minimum clearance of 40 mm should be maintained below the shelves and the top of the cabinet.

The air grills at the front and rear of the cabinet must not be covered at all.

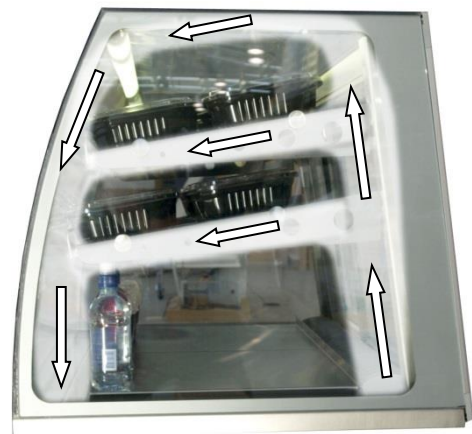

Close all Doors

It is important to keep all cabinet doors closed. If doors are not fully closed, an even temperature will not be maintained within the cabinet.

Turn on Lights

When ready for service, turn on the cabinet lights.

Routines

REFRIGERATED CABINETS - OPERATION

After Hours Ideally, cabinets should not be turned off after hours or at night. Products can either be left in the cabinet or placed in night storage. Shut the cabinet doors and turn off the lights. The cabinet will then operate on minimum load, and stay cold, ready for instant operation when next required.

If the cabinet is turned off, allow it to run for about half an hour before replacing the pre-chilled products.

Cleaning Since the cabinet needs to be switched off during cleaning operations, it is best to clean it at the end of the working day. The cabinet will then have time to recover its normal operating temperature, before replacing the products.

Once the cleaning is finished, turn the cabinet on again, turn off the lights and shut the doors. The cabinet will cool down under minimum load and be ready for the next day's use.

De-frost Cycle The cabinet will de-frost automatically six times per day. The cabinet should NOT be temperature tested within ½ hour of a de-frost programme being completed.

The first defrost cycle will occur four hours after the cabinet is first switched on.

Door Opening The cabinet is designed to maintain food at a temperature of 2° to 4°C. The refrigeration system is designed to maintain this temperature with the doors being opened and closed up to 60 times per hour.

If the doors are left open for an extended period the temperature will rise. Once the doors are shut the temperature will take sometime to fall to the normal operating level. The longer the doors are open the longer the time to restore normal operating temperature.

TROUBLE SHOOTING

FAULT	POSSIBLE CAUSE	REMEDY
Cabinet does not operate/start	The mains isolating switch on the wall, circuit breaker or fuses are off at the power board	Turn isolating switch circuit breaker or fuses on
	Internal fuse has blown	<i>Have wiring checked and replace fuse (5A Slow Blow)</i>
	The main switch on the cabinet is OFF	Turn the main switch ON
Cabinet does not reach temperature	One or more doors is open	Close doors and re-test temperature after 30 minutes
	Too much product in cabinet	Remove some product
	Ventilation grills are blocked	Vacuum or remove blockage
	Product blocking air grill	Place product on shelves
	Evaporator coil fins blocked	Clean coil fins of food etc.
	Trays obstructing air flow	Re-position trays on shelves
	Thermostat needs adjustment	<i>Adjust controller</i>
	Ambient temperature > 25°C	Adjust store air conditioning
	Damaged or missing door seal	<i>Replace door seal</i>
	Evaporator coil iced up	<i>De-ice coil</i>
	Condenser radiator blocked	<i>Remove dust and debris</i>
	Thermostat faulty	<i>Replace controller</i>
	Temperature probe damaged	<i>Replace temperature probe</i>
	Defrost cycle not suitable	<i>Adjust to match environment</i>
Fans not operating	<i>Have fans checked/replaced</i>	
Cabinet lights not working	The light switch is OFF	Turn light switch ON
	A failed LED power supply	<i>Replace the power supply</i>
	An LED strip has failed	<i>Replace the LED assembly</i>
	Fuse has blown	<i>Have wiring checked and replace fuse (5A Slow Blow)</i>
Doors are not sliding smoothly	Door not in track	Install door correctly in track
	Debris in track	Clean door tracks (see cleaning)
	Lack of lubricant	Apply food grade lubricant to door track
Aluminium parts corroded	Caustic detergent damage	Order replacement parts

Service Personnel Only

The table entries in ***italics*** indicate actions to be taken only by qualified Service Personnel.

CLEANING

Cautions

REFRIGERATED CABINETS - CLEANING

Power **ALWAYS TURN THE POWER SUPPLY OFF BEFORE CLEANING.**

Water THIS UNIT IS NOT WATERPROOF. DO NOT USE A WATER JET SPRAY TO CLEAN THE INTERIOR OR EXTERIOR OF THIS CABINET.

Exterior

REFRIGERATED CABINETS - CLEANING

Metal Surfaces Stainless steel or aluminium surfaces should be cleaned with hot soapy water or a good quality metal cleaning compound. **DO NOT** clean surfaces with abrasive pads or cleaners (e.g. Scotchbrite pads or Jif), as stainless steel and aluminium surfaces will be damaged.

Glass All glass should be cleaned using a good quality glass cleaner and a clean cloth.
DO NOT use abrasive pads or cleaners, because they will damage the surface of the glass.

Sliding Doors



Sliding glass doors are located by plastic guides at the top and bottom.

The doors can be removed for cleaning by sliding the door to a central position, placing hands either side of the door, lifting it up and then swinging it out at the bottom.

When replacing doors, make sure that they are located in the correct slots, top and bottom. The left door should be in the inner slots, and the right door in the outer slots.

Sliding door tracks should be vacuumed out regularly to keep doors sliding freely.

Continued on next page

Exterior cont.

REFRIGERATED CABINETS - CLEANING

Louvers

Use a vacuum cleaner to remove dust and fluff from all of the ventilation louvers.

This will maintain the refrigeration efficiency, and prevent overheating.

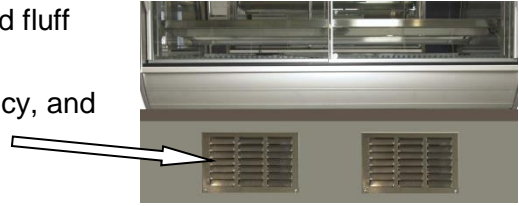

Interior

REFRIGERATED CABINETS - CLEANING

Access to the Cabinet Base Cavity



Remove the doors.

Lift out the deck trays and plastic louvers.

Remove the two screws, securing the fan deck.



Lift up the fan deck, and stand it vertically.

Lift the cover plate off the evaporator coil and disengage it from the chassis.



The whole of the cabinet interior is now accessible for cleaning.

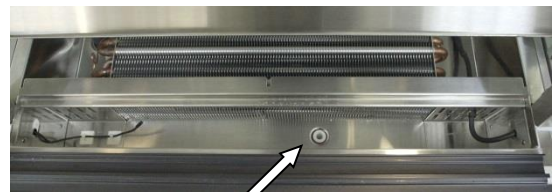

Drain Hole

Continued on next page

Interior cont.*REFRIGERATED CABINETS - CLEANING*

Cleaning the Base Cavity

Sweep out, or use a vacuum cleaner, to remove any debris from the cabinet base cavity. **Make sure that the condensate drain hole is clean.**

A Wet-and-Dry vacuum cleaner should be used, since there is likely to be some water in the bottom. Finally, wipe out the bottom with a damp sanitized cloth.

Do not pour water into the base, or the condensate container will overflow.

Cooling Fins

If there is food lodged in the cooling fins, it is best to use a wet and dry vacuum cleaner to suck out the food. **DO NOT** attempt to hose food parts from fins.

Caution: The fins are very sharp. Take extra care when cleaning this area. Do not bend the fins over, as this would restrict the air flow and degrade cabinet performance.

**Temperature Probes**

Take care not to damage or move the temperature probes, when cleaning the cooling fins.

One probe is located on the fan side of the cooling coil, in free air. A second probe is inserted between the fins of the cooling coil on the air exit side.

Do NOT move the probes.

Condensate Container

The condensate container is only designed to handle cooling-coil defrosting liquid that drains from the well.

DO NOT fill the well with liquid, or attempt to hose out as condensate container will overflow and leak onto floor.

Trays, Shelves & Air Grills

Stainless steel trays, shelves, grills etc. should be cleaned with hot soapy water. Do not use abrasive pads or cleaners (e.g. Scotchbrite pads or Jif), as these may damage surfaces.

Warning: Dishwasher detergents will damage any anodised aluminium parts.

Re-assembly

Take care to re-assemble panels and covers correctly, as any air gaps can adversely effect air circulation and the cabinet temperature.

Routines

REFRIGERATED CABINETS - CLEANING

Schedules To maintain optimum performance, cleaning schedules must be regular and thorough.

Warning **Failure to carry out routine cleaning/servicing schedules will void the warranty on the refrigeration equipment.**

Condenser Assembly



For efficient refrigeration performance, the condenser and radiator must be kept clean. Failure to do this will lead to a build up of dust, and restricted airflow will prevent the unit from working properly. The compressor may overheat and the cabinet temperature may rise.

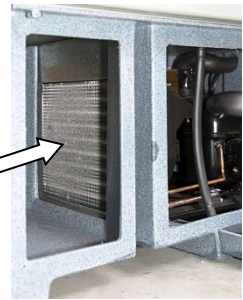

Regular vacuuming will prevent a build up of dust and fluff, however, three monthly service checks by a refrigeration engineer, which include cleaning the condenser with compressed air, are mandatory.

Be very careful not to bend or damage the soft aluminium fins when vacuuming the radiator. If the fins are flattened, airflow will be restricted and overheating will result.

Condensate



The condensate container should be checked each time the cabinet is cleaned.

The quantity of water will depend on the relative humidity and cabinet contents. Natural evaporation can be sufficient to keep the container empty, but if water has accumulated, it should be removed and emptied regularly.

If preferred, particularly in high humidity situations, the condensate can be plumbed to a drain.

Inspection As part of the cleaning routine, the controls, mechanical parts and electrical wiring should be inspected for damage, deterioration or need of adjustment.

Fault Correction If any small faults are found, have them attended to promptly by a competent serviceman. Don't wait until they cause a complete breakdown.

INSTALLATION

Regulations

REFRIGERATED CABINETS - INSTALLATION

Compliance with Local Requirements

It is very important that your inline food cabinet is installed correctly and that the operation is correct before use. Installation must comply with local electrical, health & safety and hygiene requirements.

Setting Up

REFRIGERATED CABINETS - INSTALLATION

Unpacking

Unpack and check unit for damage and report any damage to the carrier and supplier. Report any deficiencies to your supplier.

The display cabinet is supplied fully assembled, but the compressor unit and shelf trays are packed separately.

Site Preparation

Ensure the cabinet location and any bench cut outs are made to the precise measurements shown in the Mechanical Drawings. Position the cabinet in its allocated working position. Use a spirit level to ensure the cabinet is level from side to side and front to back. (If this is not carried out, water may accumulate in the cabinet well, and uneven temperature distribution could also occur).

Cabinet Preparation

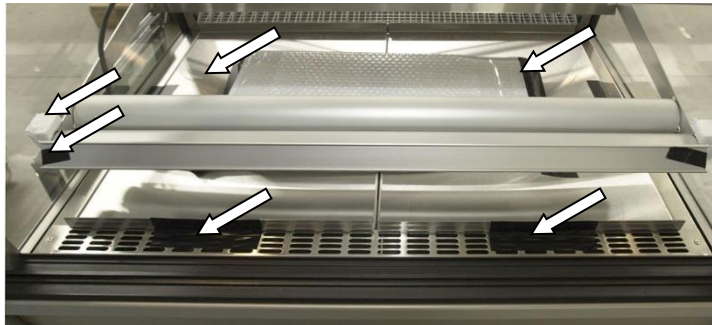

Remove all protective plastic film, tapes, ties and packers, used to prevent movement during transit.

Lift out the deck trays to gain access to the cabinet well. Be sure to replace them as shown.

Shelf Trays

Remove the shelf trays from their packing, peel off the protective plastic coating and assemble them on the support members.

Fit the correct size trays for each shelf level.

Continued on next page



Setting Up cont.

REFRIGERATED CABINETS - INSTALLATION

Grounding

WARNING: THIS APPLIANCE MUST BE GROUNDED TO EARTH

The grounding lead, in the mains cable, must always be connected to ground.

A binding post is also provided adjacent to the control gear chassis, to allow the cabinet to be bonded to a surge grounding conductor or to adjacent equipment, should this be required.

Power Supply

Before connecting to the power supply, check that the local supply is correct to that shown on the rating plate, located on the rear of the cabinet.

Isolation

If the cabinet is not connected by a plug and socket, but is hard wired to the mains supply, a means of isolation must be provided.

If a plug and socket are used, they should still be accessible after the cabinet is installed.

Location

REFRIGERATED CABINETS - INSTALLATION

Ventilation Adequate ventilation must be provided for the condenser unit.

Air Flow Requirements

If the condenser is in an enclosed space, grills must be provided to allow cool air to enter and warm air to exit.

It is not sufficient to provide just one or two grills, as the air will tend to re-circulate within the enclosure, resulting in poor refrigeration performance.

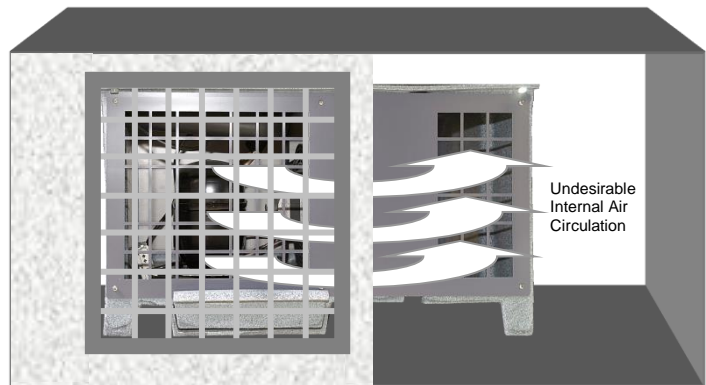

Air Duct

A duct must be constructed to separate the inlet side of the condenser radiator from the exhausted warm air.

This will prevent internal re-circulation of warm air.

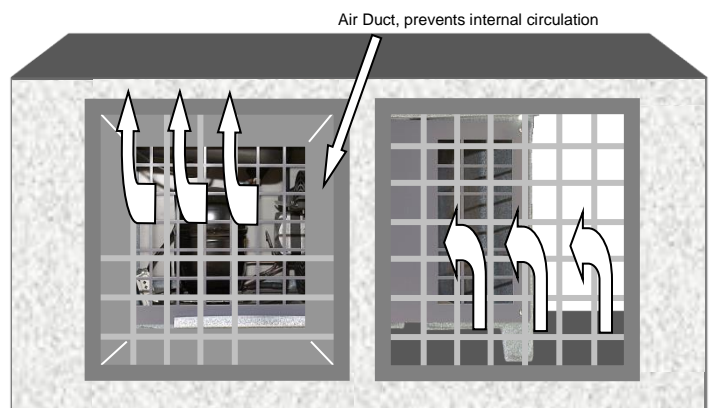

Access

Access to the back of the cabinet is required for loading, cleaning, re-positioning of shelves and operation of the control panel. Access to the condensate drainage tray is also required, (see above).

Condenser Unit, remote installation

REFRIGERATED CABINETS - INSTALLATION

Refrigerant Connections (Refrigeration Engineer)

Refrigeration pipes must be brazed between the cabinet stubs and the condenser unit. After the pipes have been fitted, the refrigeration engineer will have to charge the system with R134A refrigerant.

The charges indicated in the Specification table may be used as a starting charge, but the final charge will depend on the distance between the cabinet and the condensing unit.



Temperature Probe (Electrician)

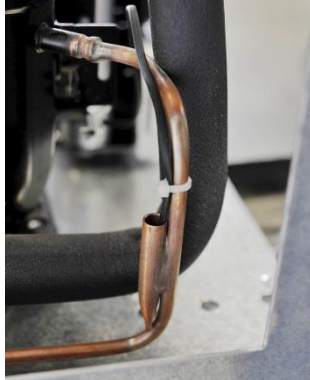

The condenser temperature probe is pre-connected to the refrigeration controller, and must be inserted in the mounting pocket on the discharge pipe of the compressor.

Power Connections (Electrician)

Cable, for connection to the condenser unit, is already connected to the display cabinet. Sufficient length is provided for spacing up to five metres.

The three-core lead without a plug should be connected to the condenser assembly, phase, neutral and earth terminals. If the lead is not long enough to reach the condenser location, a terminal box should be fitted close to the cabinet, and the power feed extended to the condenser via fixed wiring.

Livery

REFRIGERATED CABINETS - INSTALLATION

Custom Inserts The silver anodised extrusions incorporate grooves, which allow appropriately coloured or printed strips of decorative laminate to be inserted. The strips are held captive by the cabinet ends.

The top strips can be easily slid upwards into the top groove, and then down into the bottom one.



The lower strip is held captive by the cabinet ends, and has to be bowed for removal and insertion.



Insert the upper edge into the narrow groove, closest to the curved surface, bow the strip to insert the end into the lower groove, then, use your thumbs to work the rest of the strip into place.

If the strip is hard to bend, a length of wooden dowel can be placed underneath to aid bowing. The dowel should be progressively withdrawn as the strip is inserted.

Note: Most metals are too rigid for insertion in this position.

Maximum strip thickness is 0.75mm. See Mechanical Drawings for dimensions.

SERVICING

Control Gear

REFRIGERATED CABINETS - SERVICING

Location The electrical control gear is located in the top of the cabinet.

Remove the top plate to access the control gear.

The chassis has power supplies for the lights, a phase-shift capacitor for the evaporator fan, the refrigeration controller and two protective fuses.



Lighting

REFRIGERATED CABINETS - SERVICING

Caution Do not service lights without isolating the cabinet from the mains supply.

Test Lighting Components Before replacing an LED strip, check that its power supply is working.

If there is no dc voltage at the output, the power supply should be replaced.

If there is a dc output, the LED strip must be replaced.

Access to LED Strips The LED strips are protected with plastic covers. These clip into grooves in the aluminium extrusion.

Remove the plastic cover to access the LED strip.

The top light assembly is different from the shelf lights, so the correct replacement unit must be used.

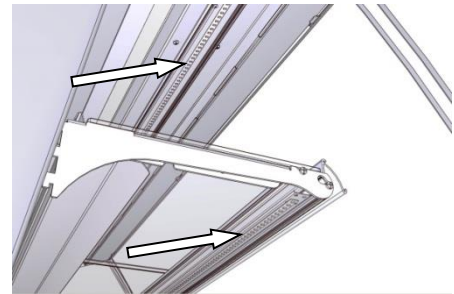

LED Strip Replacement Individual LED modules cannot be replaced. A complete light unit must be used.

Connection is made with a plug and socket. Disengage the supply lead from the metalwork, and re-assemble it to the replacement unit.

Replace the plastic cover.

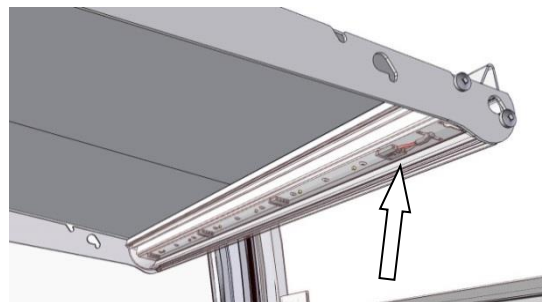

Refrigeration

REFRIGERATED CABINETS - SERVICING

Caution **DO NOT attempt to service the refrigeration equipment without isolating the cabinet at the supply switch or by unplugging it from the supply.**

Condenser Assembly

For efficient refrigeration performance, the condenser radiator must be kept clean. Failure to do this will lead to a build up of dust, and the restricted airflow will prevent the unit from working properly. The compressor may overheat and the cabinet temperature may rise.

Regular vacuuming will prevent a build up of dust and fluff, however, three monthly service checks by a refrigeration engineer, which include cleaning the condenser with compressed air, are mandatory.

Be very careful not to bend or damage the soft aluminium fins when vacuuming the radiator. If the fins are flattened, airflow will be restricted and overheating will result.

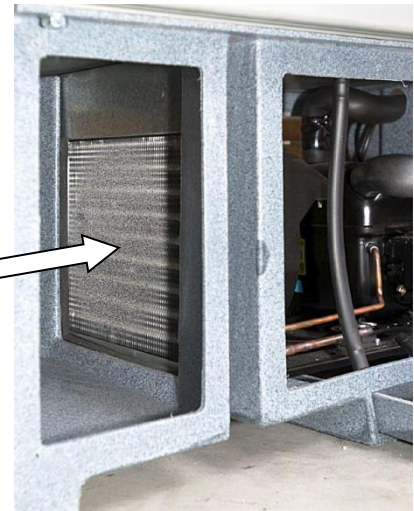

Ventilation Panels

All ventilation panels should be kept free of dust by regular vacuuming, so that air flow is not restricted.

Cabinet Air Circulation Fan

The cabinet air circulation fan is located in the base of the cabinet. Access is gained by removing the deck trays.

The fan is a single phase, capacitor run unit, with the capacitor housed in the top of the cabinet, along with the lighting control gear etc.

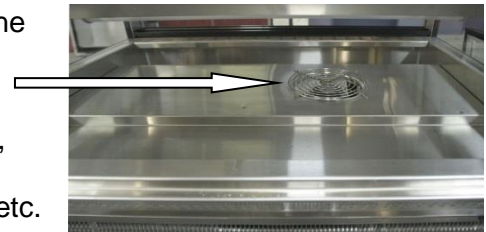

Continued on next page

Refrigeration cont.

REFRIGERATED CABINETS - SERVICING

Temperature Regulator XR40CX



Model XR40CX is a microprocessor based controller.

It has three NTC probe inputs, the first one for temperature control, the second one, located on the evaporator, to control the defrost termination temperature, the third one, located on the condenser discharge

pipe, to signal a condenser temperature alarm.

Since the temperature control probe is located on the return air side of the coil, (Air On), the measured temperature will be higher than the average air temperature inside the cabinet.

The HOT KEY output allows one to programme the controller by means the HOT KEY programming keyboard.

The instrument is fully configurable through special parameters that can be easily programmed through the keyboard.

XR40CX Compressor Control

The regulation is performed according to the temperature measured by the thermostat probe with a positive differential from the set point: if the temperature increases and reaches set point plus differential the compressor is started and then turned off when the temperature reaches the set point value again.

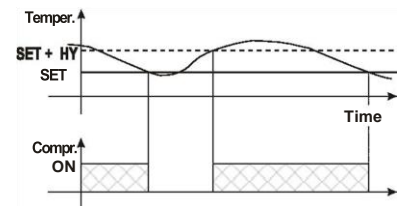

In case of a fault in the thermostat probe the start and stop of the compressor are timed through parameters **CO_n** and **CO_F**.

XR40CX Defrost Control

Parameters are used to control the interval between defrost cycles (IdF), its maximum length (MdF) and two defrost modes: timed or controlled by the evaporator's probe (P2P).

In this cabinet, the start of the defrost cycle is timed, but the cycle will be terminated as soon as the defrost probe reaches the pre-determined temperature.







At the end of defrost dripping time is started, its length is set in the FSt parameter. With FSt =0 the dripping time is disabled

Continued on next page





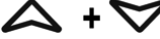

Refrigeration cont.

REFRIGERATED CABINETS - SERVICING

XR40CX Key Functions

KEY	FUNCTION
SET	To display target set point; in programming mode it selects a parameter or confirm an operation
	(DEF) To start a manual defrost
	(UP): To see the max. stored temperature; in programming mode it browses the parameter codes or increases the displayed value
	(DOWN): To see the min stored temperature; in programming mode it browses the parameter codes or decreases the displayed value
	To switch the instrument off, if onF = oFF. Not enabled
	To lock & unlock the keyboard
SET + 	To enter into programming mode
SET + 	To return to the temperature display mode

XR40CX LED Functions

LED	MODE	FUNCTION
	ON	Compressor enabled
	Flashing	Anti-short cycle delay enabled
	ON	Defrost enabled
	Flashing	Drip time in progress
	ON	An alarm is occurring
	ON	Continuous cycle is running
	ON	Energy saving enabled
°C/°F	ON	Measurement unit
°C/°F	Flashing	Programming phase

Continued on next page

Refrigeration cont.

REFRIGERATED CABINETS - SERVICING

XR40CX Min & Max Recorded Temperature

Press and release the  key.

Lo will be displayed followed by the minimum temperature recorded.

Press the  key again or wait 5s to restore the normal display.

Press and release the  key.

Hi will be displayed followed by the maximum temperature recorded.

Press the  key again or wait 5s to restore the normal display.

XR40CX Reset Max/Min Temperature Memory

Press the **SET** key for more than 3s, while the max. or min. temperature is displayed. (**rSt** message will be displayed)



To confirm the operation the **rSt** message starts blinking and the normal temperature will be displayed.

XR40CX Display the Set- point

To show the set-point value, press and immediately release the **SET** key.

Press and immediately release the **SET** key or wait for 5 seconds to display the probe temperature again.

XR40CX Change the Set-point

To change the set-point value, press the **SET** key for more than 2 seconds; The value of the set-point will be displayed and the °C or °F LED starts blinking; To change the set value push the  or  arrows within 10s.





To memorise the new set-point value push the **SET** key again or wait 10s.

XR40CX Start a Manual Defrost

To start a manual defrost, press the  (DEF) key for more than 2 seconds.

XR40CX Programming Mode

Enter the Programming mode by pressing the **SET+** keys for 3s (the °C or °F LED starts blinking).

- Use the  or  keys to select the required parameter.
- Press the **SET** key to display its value.
- Use the  or  keys to change its value.
- Press **SET** to store the new value and move to the following parameter.

To exit Programming mode, press **SET+** or wait 15s without pressing a key.

NOTE: the set value is stored even when the procedure is exited by waiting for the time-out to expire.

Continued on next page

Refrigeration cont.

REFRIGERATED CABINETS - SERVICING

XR40CX The Hidden Menu

The hidden menu includes all the parameters of the instrument.

TO ENTER THE HIDDEN MENU

- Enter the Programming mode by pressing the **SET+▼** keys for 3s, (the °C or °F LED starts blinking).
- Release the keys, then press the **SET+▼** keys again, for more than 7s. The **Pr2** label will be displayed immediately followed from the **Hy** parameter.

NOW YOU ARE IN THE HIDDEN MENU.

- Select the required parameter.
- Press the **SET** key to display its value
- Use ▲ or ▼ to change its value.
- Press **SET** to store the new value and move to the following parameter.
- To exit: Press **SET+▲** or wait 15s without pressing a key.

NOTE 1: If no parameter is present in **Pr1**, after 3s the **noP** message is displayed. Keep the keys pushed till the **Pr2** message is displayed.

NOTE 2: The set value is stored even when the procedure is exited by waiting for the time-out period to expire.

TO MOVE A PARAMETER FROM THE HIDDEN MENU TO THE FIRST LEVEL AND VICEVERSA.

Each parameter present in the HIDDEN MENU can be removed or put into "THE FIRST LEVEL" (user level) by pressing **SET+▼**

In HIDDEN MENU when a parameter is present in the First Level the decimal point is shown.

XR40CX Locking and Unlocking the Keyboard

To lock the keyboard, press the ▲ + ▼ keys for more than 3 s.

The **POF** message will be displayed, followed by the previous temperature display.

If a key is pressed more than 3s the **POF** message will be displayed.

To unlock the keyboard, press the ▲ + ▼ keys for more than 3s, till the **Pon** message is displayed.

Continued on next page



Refrigeration cont.

REFRIGERATED CABINETS - SERVICING

FPG Settings

Note that the following settings are Dixell factory defaults. Refer to the Specification section for the correct FPG settings for your cabinet.

Dixell Default Settings

Label	Name	Range	Default Setting
Set	Set point	LS÷ US	-5.0
Hy	Differential	0,1÷25.5°C/ 1÷ 255°F	2.0
LS	Minimum set point	-50°C÷SET/-58°F÷SET	-50.0
US	Maximum set point	SET÷110°C/ SET ÷ 230°F	110
Ot	Thermostat probe calibration	-12÷12°C /-120÷120°F	0.0
P2P	Evaporator probe presence	n=not present; Y=pres.	Y
OE	Evaporator probe calibration	-12÷12°C /-120÷120°F	0.0
P3P	Third probe presence	n=not present; Y=pres.	n
O3	Third probe calibration	-12÷12°C /-120÷120°F	0
P4P	Fourth probe presence	n=not present; Y=pres.	n
O4	Fourth probe calibration	-12÷12°C /-120÷120°F	0
OdS	Outputs delay at start up	0÷255 min	0
AC	Anti-short cycle delay	0 ÷ 50 min	1
rtr	P1-P2 percentage for regulation	0 ÷ 100 (100=P1 , 0=P2)	100
CCt	Continuous cycle duration	0.0÷24.0h	0.0
CCS	Set point for continuous cycle	(-55.0÷150,0°C) (-67÷302°F)	-5
CO _n	Compressor ON time with faulty probe	0 ÷ 255 min	15
CO _F	Compressor OFF time with faulty probe	0 ÷ 255 min	30
CF	Temperature measurement unit	°C ÷ °F	°C
rES	Resolution	in=integer; dE= dec.point	dE
Lod	Probe displayed	P1;P2	P1
rEd2	X-REP display	P1 - P2 - P3 - P4 - SEt - dtr	P1
dLy	Display temperature delay	0 ÷ 20.0 min (10 sec.)	0
dtr	P1-P2 percentage for display	1 ÷ 99	50
tdF	Defrost type	EL=el. heater; in= hot gas	EL
dFP	Probe selection for defrost termination	nP; P1; P2; P3; P4	P2
dtE	Defrost termination temperature	-50 ÷ 50 °C	8
ldF	Interval between defrost cycles	1 ÷ 120 ore	6
MdF	(Maximum) length for defrost	0 ÷ 255 min	30
dSd	Start defrost delay	0÷99min	0
dFd	Displaying during defrost	rt, it, SEt, DEF	it
dAd	MAX display delay after defrost	0 ÷ 255 min	30
Fdt	Draining time	0÷120 min	0
dPo	First defrost after start-up	n=after ldF; y=immed.	n
dAF	Defrost delay after fast freezing	0 ÷ 23h e 50'	0.0
ALc	Temperature alarms configuration	rE= related to set; Ab = absolute	Ab
ALU	MAXIMUM temperature alarm	Set÷110.0°C; Set÷230°F	110
ALL	Minimum temperature alarm	-50.0°C÷Set/ -58°F÷Set	-50.0

Continued on next page

Refrigeration cont.

REFRIGERATED CABINETS - SERVICING

Dixell Default Settings cont.

Label	Name	Range	Default Setting
AFH	Differential for temperat. alarm recovery	(0,1 °C÷25,5°C) (1 °F÷45°F)	1
ALd	Temperature alarm delay	0 ÷ 255 min	15
dAO	Delay of temperature alarm at start up	0 ÷ 23h e 50'	1.3
AP2	Probe for temperat. alarm of condenser	nP; P1; P2; P3; P4	P4
AL2	Condenser for low temperat. alarm	(-55 ÷ 150°C) (-67÷ 302°F)	-40
AU2	Condenser for high temperat. alarm	(-55 ÷ 150°C) (-67÷ 302°F)	110
AH2	Differ. for condenser temp. alar. recovery	[0,1 °C ÷ 25,5°C] [1 °F ÷ 45°F]	5
Ad2	Condenser temperature alarm delay	0 ÷ 254 (min.) , 255=nU	15
dA2	Delay of cond. temper. alarm at start up	0.0 ÷ 23h 50'	1,3
bLL	Compressor OFF for condenser low temperature alarm	n(0) - Y(1)	n
AC2	Compressor OFF for condenser high temperature alarm	n(0) - Y(1)	n
i1P	Digital input polarity	oP=opening; CL=closing	cL
i1F	Digital input configuration	EAL, bAL, PAL, dor; dEF; Htr, AUS	EAL
did	Digital input alarm delay	0÷255min	5
Nps	Number of activation of pressure switch	0 ÷15	15
odc	Compress status when open door	no; Fan; CPr; F_C	no
rrd	Regulation restart with door open alarm	n - Y	y
HES	Differential for Energy Saving	(-30°C÷ 30°C) (-54°F÷ 54°F)	0
Adr	Serial address	0÷247	1
PbC	Kind of probe	Ptc; ntc	ntc
onF	on/off key enabling	nu, oFF; ES	nu
dP1	Room probe display	--	--
dP2	Evaporator probe display	--	--
dP3	Third probe display	--	--
dP4	Fourth probe display	--	--
rSE	Set operating value	actual set	--
rEL	Software release	--	--
Ptb	Map code	--	--

XR40CX Hot Key

To program the controller from a Hot Key:

- Turn OFF the instrument.
- Insert a programmed Hot Key into the 5 PIN socket and then turn the Controller ON.
- The parameter list of the Hot Key is automatically downloaded into the Controller memory, the **doL** will blink, followed a by a flashing **End**.
- After 10 seconds the instrument will restart working with the new parameters.
- Remove the Hot Key.

NOTE the message **Err** is displayed if programming fails. In this case turn the unit off and then on again, if you want to restart the download again, or remove the Hot Key to abort the operation.

Continued on next page

Refrigeration cont.

REFRIGERATED CABINETS - SERVICING

XR40CX Alarm Signals

Message	Cause	Outputs
P1	Room probe failure	Compressor output acc. to par. Con and COF
P2	Evaporator probe failure	Defrost end is timed
P3	Third probe failure	Outputs unchanged
P4	Fourth probe failure	Outputs unchanged
HA	Maximum temperature alarm	Outputs unchanged.
LA	Minimum temperature alarm	Outputs unchanged.
HA2	Condenser high temperature	It depends on the Ac2 parameter
LA2	Condenser low temperature	It depends on the bLL parameter
dA	Door open	Compressor according to rrd
EA	External alarm	Output unchanged.
CA	Serious external alarm (i1 F=bAL)	All outputs OFF.
CA	Pressure switch alarm (i1 F=PAL)	All outputs OFF

XR40CX Alarm Recovery

Probe alarms P1, P2, P3 and P4 start some seconds after the fault in the related probe; they automatically stop some seconds after the probe restarts normal operation. Check connections before replacing the probe.

Temperature alarms HA, LA, HA2 and LA2 automatically stop as soon as the temperature returns to normal values.

Alarms EA and CA (with i1 F=bAL) recover as soon as the digital input is disabled. Alarm CA (with i1 F=PAL) recovers only by switching off and on the instrument.

XR40CX Other Messages

Message	Cause
Pon	Keyboard unlocked.
PoF	Keyboard locked
noP	In programming mode: none parameter is present in Pr1 On the display or in dP2, dP3, dP4: the selected probe is not enabled
noA	No alarm is recorded.

XR40CX Connections

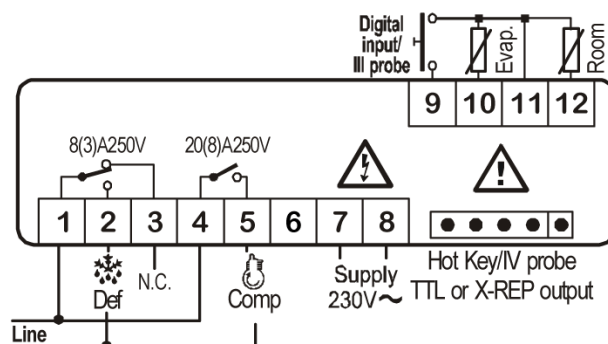

Door Seals

REFRIGERATED CABINETS - SERVICING

Seal Replacement

The doors should be removed to allow the old seals to be removed and the new ones fitted. See the Cleaning section for details.

Sliding Doors



Each sliding door has a rubber seal between the door and the cabinet end panel. The seal slides into a groove in the door extrusion, and can be withdrawn and replaced, if damaged.

A centre seal is fitted between the inner and outer doors. The Qlon seal is located in a slot in the aluminium extrusion, and can be replaced if damaged.

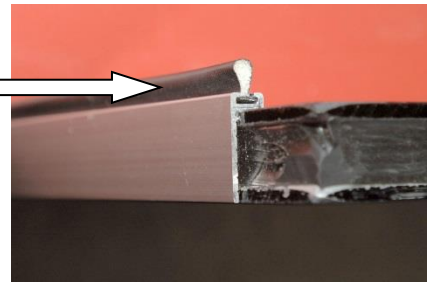

Mains Lead

REFRIGERATED CABINETS - SERVICING

Lead Replacement

If damaged, the mains lead must **ONLY** be replaced by a qualified service person.

SPECIFICATIONS

Mechanical

REFRIGERATED CABINETS - SPECIFICATIONS

	CABINET MODEL					
	IN 3C08	IN 3C12	IN 3C15	IN 3C18		
Height	769 mm	769 mm	769 mm	769 mm		
Width	800 mm	1200 mm	1500 mm	1800 mm		
Depth	661 mm	661 mm	661 mm	661 mm		
Dry Weight	80 kg	100 kg	130 kg	160 kg		
Cabinet Well Material	Stainless steel					
Cabinet Colour	Grey and natural anodised aluminium.					
Top Lighting	Standard					
Shelf Lighting	Optional					
Glass Type	Double glazed					
Front Doors	Fixed or Sliding options					
Number of Shelves	Three plus base					
Display Area	0.9 m ²	1.4 m ²	1.8 m ²	2.2 m ²		
Refrigerant	R134A	R134A	R134A	R134A		
Refrigerant charge	See Rating Label					
Condensate capacity	2.5 litres					
Climatic Class & IP	Cabinets are tested under Climate Class 3 conditions and have IP 20 ratings					

Electrical

REFRIGERATED CABINETS - SPECIFICATIONS

	CABINET MODEL					
	IN 3C08	IN 3C12	IN 3C15	IN 3C18		
Voltage	220 - 240 V 50 Hz 1 ϕ					
Power (with shelf lights)	0.6 kW	0.7 kW	0.9 kW	1.2 kW	These figures apply to integral condenser models	
Current (with shelf lights)	2.8 A	3.0 A	3.7 A	5.2 A		
Connection	3 pin plug, 10 A lead					
Temperature Range	Refrigerated 2° - 4° C Controlled Ambient 16° - 18° C					
Top Lights	1 LED Strip	1 LED Strip	1 LED Strip	1 LED Strip		
Shelf Lights	3 LED Strips	3 LED Strips	3 LED Strips	3 LED Strips		

Controller Settings

REFRIGERATED CABINETS - SPECIFICATIONS

Dixell XR40CX Settings

	Parameter	Cold Models		Controlled Ambient Models	
		Integral Condenser	Remote Condenser	Integral Condenser	Remote Condenser
Set Point	Set	2	2	16	16
Differential	Hy	2	2	2	2
Third Probe Used	P3P	Y	<i>n</i>	Y	<i>n</i>
Anti Short Cycle Delay	AC	0	0	0	0
Comp On Time - Faulty Probe	C0n	4	4	4	4
Comp Off Time - Faulty Probe	C0F	6	6	6	6
Defrost Terminate Temp	dtE	3	3	3	3
Interval Between Defrosts	ldF	4	4	4	4
Display During Defrost	dFd	DEF	DEF	DEF	DEF
Maximum Temperature Alarm	ALU	12	12	<i>110</i>	<i>110</i>
Differential For Temp Alarm	AFH	8	8	<i>1</i>	<i>1</i>
Temperature Alarm Delay	Ald	60	60	<i>15</i>	<i>15</i>
Probe For High Temp Alarm	AP2	P3	<i>nP</i>	P3	<i>nP</i>
High Temp Alarm Set Point	AU2	100	<i>110</i>	100	<i>110</i>
High Discharge Temp Alarm Diff	AH2	25	<i>5</i>	25	<i>5</i>
High Discharge Temp Alarm delay	Ad2	0	<i>15</i>	0	<i>15</i>
High Alarm Delay At Start	dA2	0	<i>1.3</i>	0	<i>1.3</i>
Comp Off For High Temp Alarm	AC2	Y	<i>n</i>	Y	<i>n</i>

Parameters shown thus are Dixell default settings



Compliance

REFRIGERATED CABINETS - SPECIFICATIONS

Safety Aspects This cabinet has been designed to comply with the relevant requirements of the following specifications:

- AS/NZS 3100 : General Requirements for Electrical Equipment
 - AS/NZS 3182 : Refrigerated Food Commercial Cabinets
 - AS/NZS 60335: Household and Similar Electrical Appliances
 - AS/NZS 3820 : Essential Safety Requirements
 - AS/NZS 4417 : Marking of Electrical Products
-

Operational Safety This appliance is not intended for use by young children or infirm persons, unless they have been adequately supervised by a responsible person, to ensure that they can use the appliance safely.

Young children should be supervised, to ensure that they do not play with the appliance.

Performance Aspects of Refrigerated Cabinets The cabinet is HACCP compliant, with the following performance:

Cabinet Operating Temperature	Average Internal Humidity	Test Conditions
+2° to +4°C	70% RH	25°C Ambient with 60% RH

Equipment Disposal

REFRIGERATED CABINETS - SPECIFICATIONS

Specialist Disposal Specialist disposal procedures are required for the safe removal of refrigerant gasses and potentially flammable foam materials.

Pentane, Dimethyl Ether, Isobutene, Butane and Propane may be present.

Hazardous Substances The cabinet does not contain any of the following, in its construction:

- Asbestos
 - PCBs (Oils containing polychlorinated biphenyl)
 - Mercury
-

Improvements

REFRIGERATED CABINETS - SPECIFICATIONS

Ongoing Development FPG reserves the right to change specifications and construction, as part of ongoing product improvement.

ELECTRICAL CIRCUIT DIAGRAMS

Model: IN 3C08

Inline 3000 Series, 800mm Refrigerated Cabinet

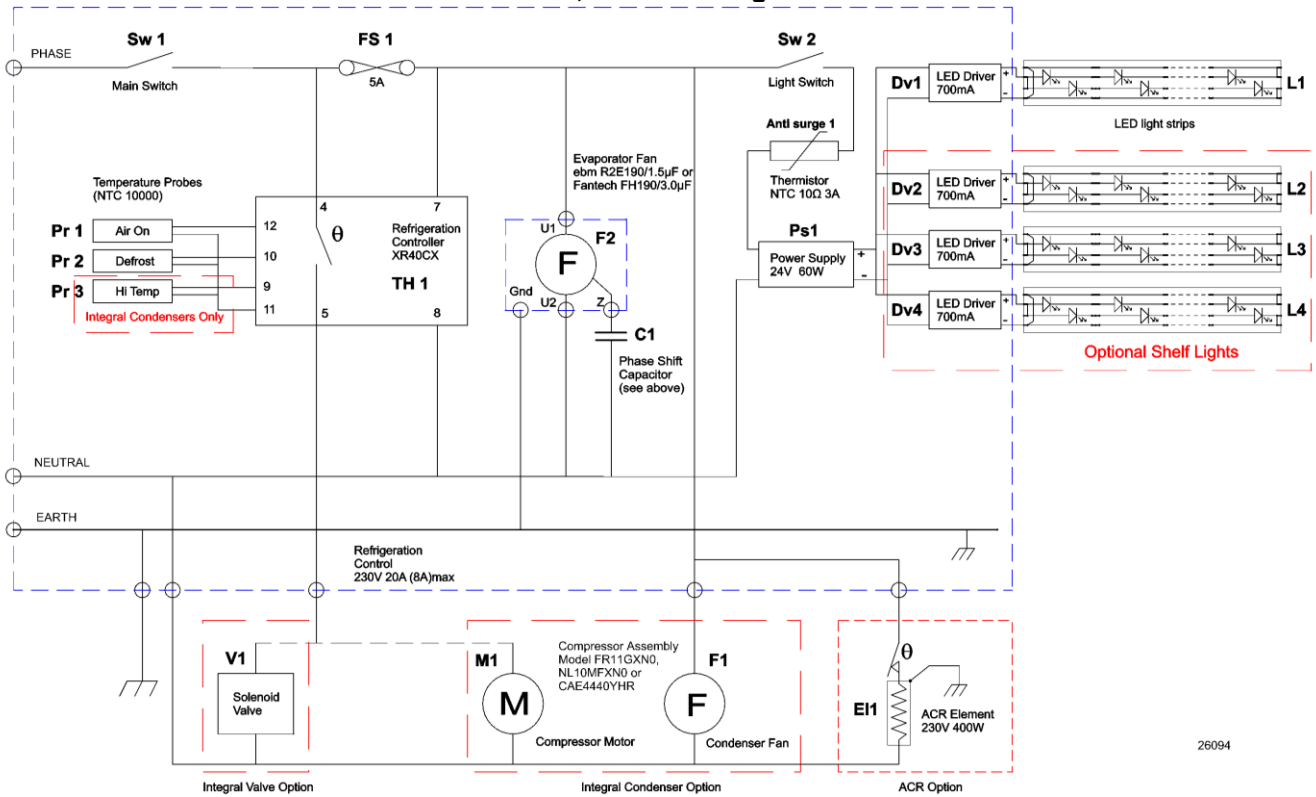

Model: IN 3C12

Inline 3000 Series, 1200mm Refrigerated Cabinet

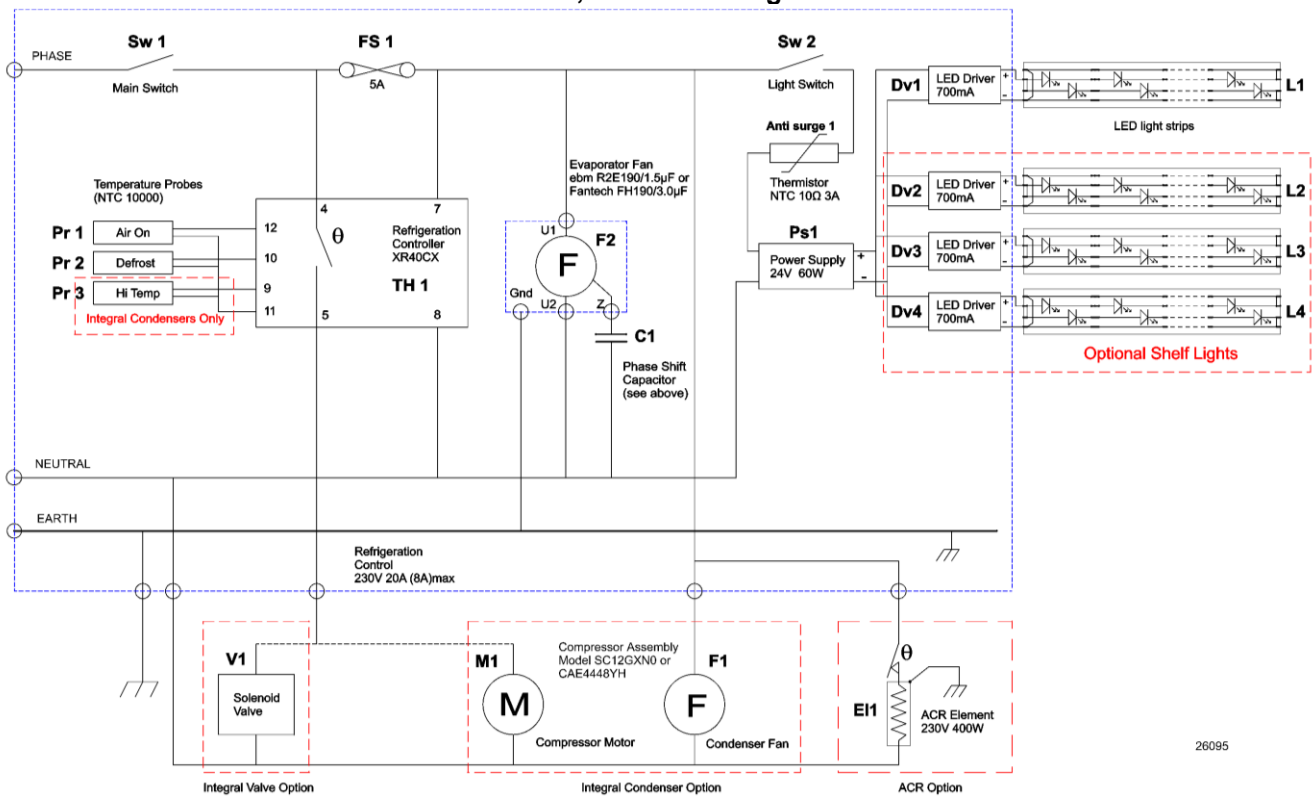

ELECTRICAL WIRING DIAGRAMS, Continued

Model: IN 3C15 **Inline 3000 Series, 1500mm Refrigerated Cabinet**

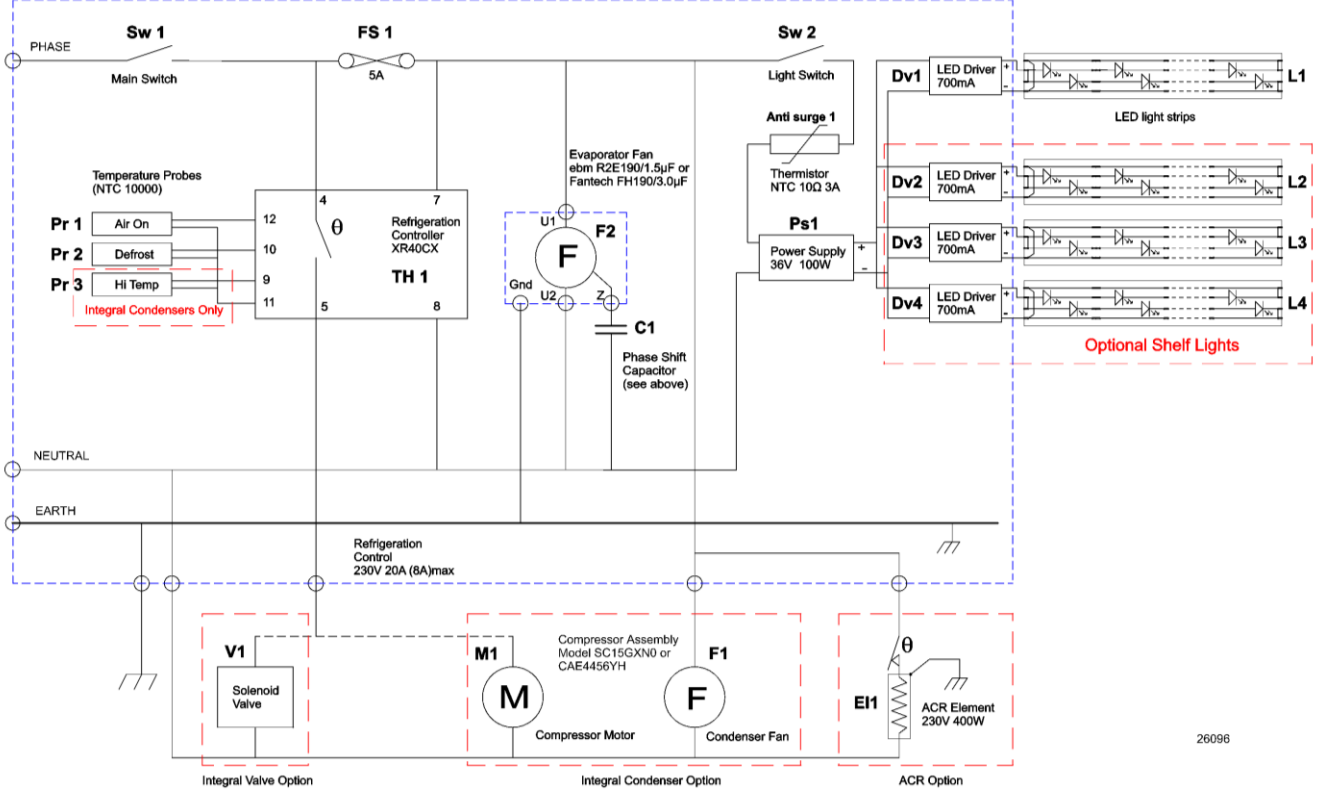

Model: IN 3C18 **Inline 3000 Series, 1800mm Refrigerated Cabinet**

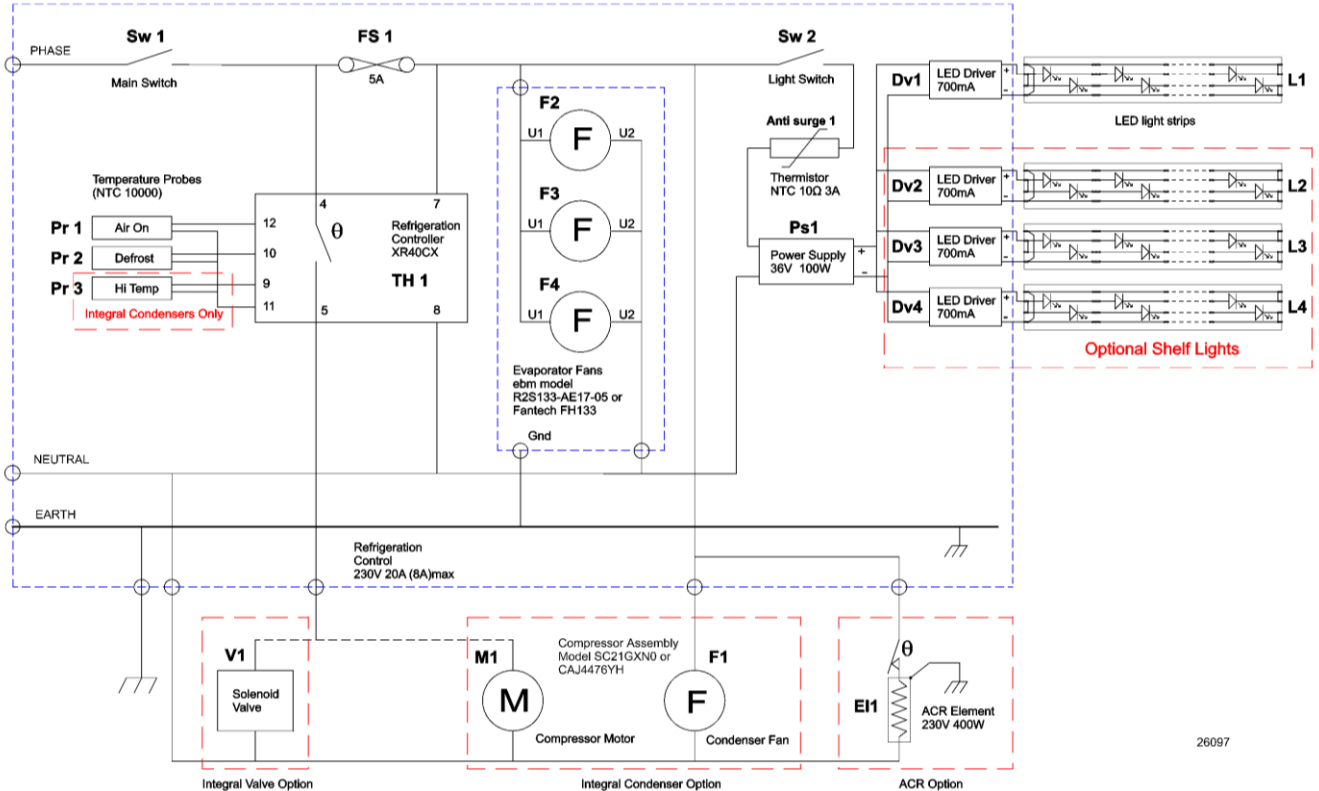

SPARE PARTS

Cabinet Serial Number

When ordering spare parts, it is important to quote the Serial Number printed on the label fixed to the control panel. This will enable FPG to trace details of the build specification of your particular cabinet, and hence ensure that spare parts are fully compatible.

To satisfy warranty conditions, and ensure optimum performance, use only FPG supplied spare parts.

Part Description	FPG Part No.
Main & Light Switch EGO	14372
Knob (Main & light switch)	14374
Fuse Link (5A, 250V, Slow Blow)	13330
Ant-surge Thermistor 10 Ohm 3A	22354
24V 60W LED power supply	21613
36V 100W LED power supply	25922
LED Driver 700mA	25762
Polycarbonate Light Cover 1120mm	18113
Polycarbonate Light Cover 720mm	18114
Top Light Replacement Kit for 3C08	69871
Shelf Light Replacement Kit for 3C08	69839
Top Light Replacement Kit for 3C12	69858
Shelf Light Replacement Kit for 3C12	69869
Top Light Replacement Kit for 3C15	69863
Shelf Light Replacement Kit for 3C15	69424
Top Light Replacement Kit for 3C18	69829
Shelf Light Replacement Kit for 3C18	69828
Cabinet Evaporator Circulation Fan ebm R2E190	12391
Cabinet Evaporator Circulation Fan Fantech FH190R	17995
Phase Shift Capacitor for R2E190 Fan (1.5 μ F 250V ac)	26230
Phase Shift Capacitor for FH190R Fan (3.0 μ F 450V ac)	14964
Cabinet Evaporator Circulation Fan ebm RS2133 (1800 cabinets only)	16104
Dixell XR40CX digital refrigeration controller	21219
NTC temperature probe (3 metre)	15870
Condenser Fan Motor (FR15GXN0 unit only)	11004
Condenser Fan Motor (CAEC4456YH & CAEC4476YH)	18870
Condenser Fan EBM M4Q045-CA03-38 (SC12,FR11,CAEC4440/4448YH)	14598
Condenser Unit FR11GXN0 (Option for 800 cabinets only)	12611
Condenser Unit NL10MFXN0 (Option for 800 cabinets only)	21734
Condenser Unit CAEC4440YHR (Option for 800 cabinets only)	17501
Condenser Unit SC12GXN0(1200 cabinets only)	12612
Condenser Unit CAEC4448YH (Option for 1200 cabinets only)	17502
Condenser Unit SC15GXN0(1500 cabinets only)	12613
Condenser Unit CAEC4456YH (Option for 1500 cabinets only)	17503
Condenser Unit SC21GXN0 (1800 cabinets only)	12615



SPARE PARTS Continued

Part Description	FPG Part No.
ACR Element 400W 230V	18274
<i>All glass parts are double glazed</i>	
LH End Glass Kit (viewed from back of cabinet)	62709
RH End Glass Kit (viewed from back of cabinet)	62710
Back Inner Sliding Door(800 cabinets only)	62658
Back Outer Sliding Door(800 cabinets only)	62659
Back Inner Sliding Door(1200 cabinets only)	62656
Back Outer Sliding Door(1200 cabinets only)	62657
Back Inner Sliding Door(1500 cabinets only)	62660
Back Outer Sliding Door(1500 cabinets only)	62661
Back Inner Sliding Door(1800 cabinets only)	62821
Back Outer Sliding Door(1800 cabinets only)	62820
Front Inner Curved Sliding Door (800 cabinets)	63338
Front Outer Curved Sliding Door (800 cabinets)	63339
Front Inner Curved Sliding Door (1200 cabinets)	63336
Front Outer Curved Sliding Door (1200 cabinets)	63337
Front Inner Curved Sliding Door (1500 cabinets)	63340
Front Outer Curved Sliding Door (1500 cabinets)	63341
Front Inner Curved Sliding Door (1800 cabinets)	63509
Front Outer Curved Sliding Door (1800 cabinets)	63510
Front fixed glass kit (800)	62570
Front fixed glass kit (1200)	62645
Front fixed glass kit (1500)	62651
Front fixed glass kit (1800)	62755
Slide-in rubber door seal	11424
Qlon door seal	12922
Plastic Air Grill	12480
Joinery ventilation grill 340mm x 340mm	56090
Product Manual for Inline 3000 Series Refrigerated Cabinets	26119

MECHANICAL DRAWINGS

Dimensions

REFRIGERATED CABINETS - MECHANICAL DRAWINGS

IN-3C08/12/15/18

The following illustrations show the integral condenser version of the cabinets. The 400 mm high base enclosure is not present on the remote condenser versions.

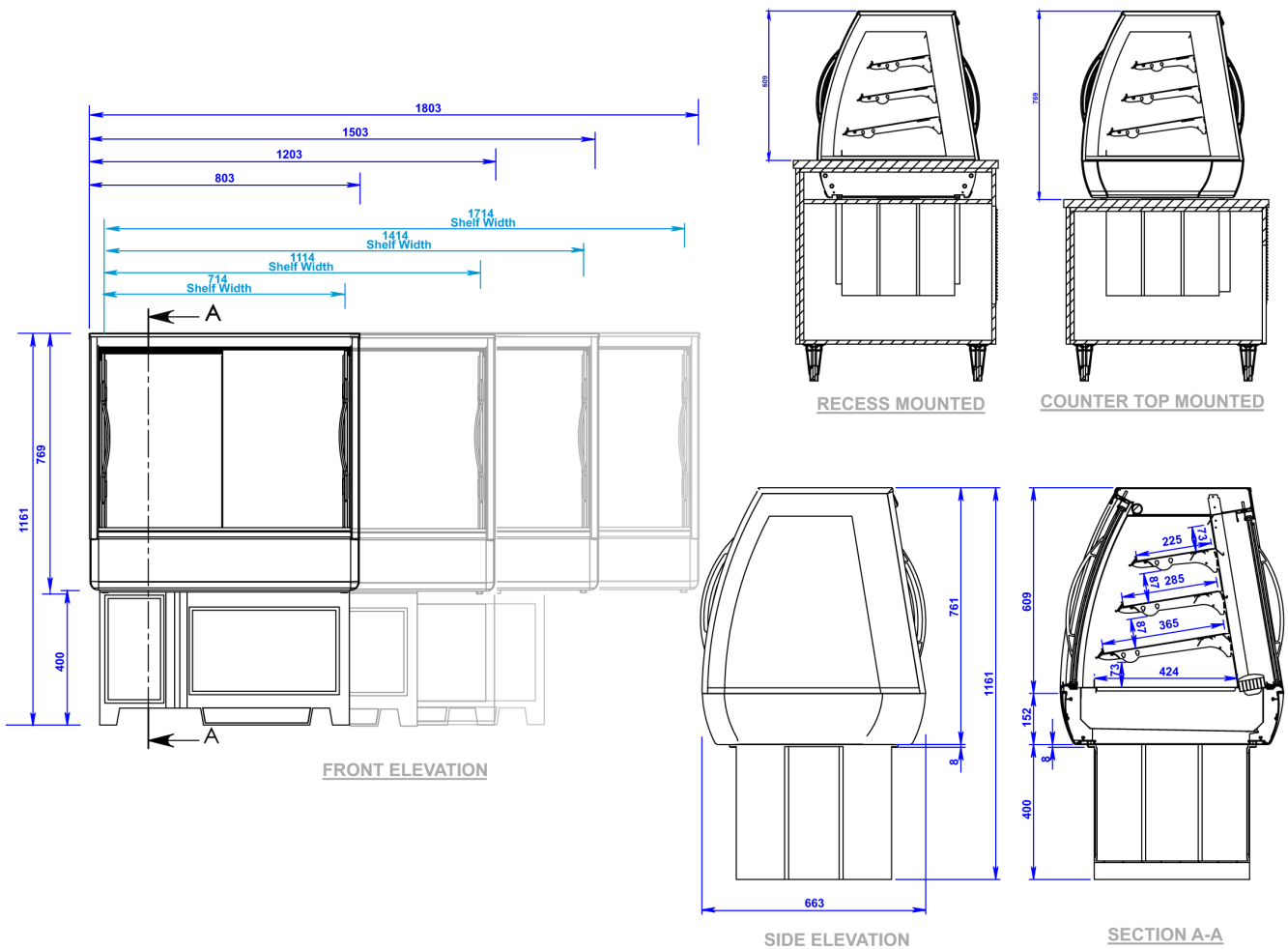

Dimensions cont.

REFRIGERATED CABINETS - MECHANICAL DRAWINGS

Cabinet Variants

The drawings show the common overall dimensions for 800mm, 1200mm, 1500mm and 1800mm cabinets.

The cabinets can have a single fixed front glass, in place of the twin sliding doors shown.

Livery

Top Insert 749 / 1149 / 1449 / 1749 mm long x 50 mm wide

Bottom Insert 754 / 1154 / 1454 / 1754 mm long x 134 mm wide

Colour / Text Inserts

Max. thickness
0.75 mm

If custom livery is applied to the cabinet, the insert material must be flexible, such as *Formica* decorative laminate or plastic sheet.

Most metals cannot be flexed sufficiently for insertion in the lower position.

Bench Cut-outs

REFRIGERATED CABINETS - MECHANICAL DRAWINGS

In Bench Mounting

Remove the decorative end panels from the base, to allow in bench mounting.

The following diagram shows the aperture dimensions, which will allow the cabinet well to enter the bench. The cabinet deck trays will then be just above bench height.

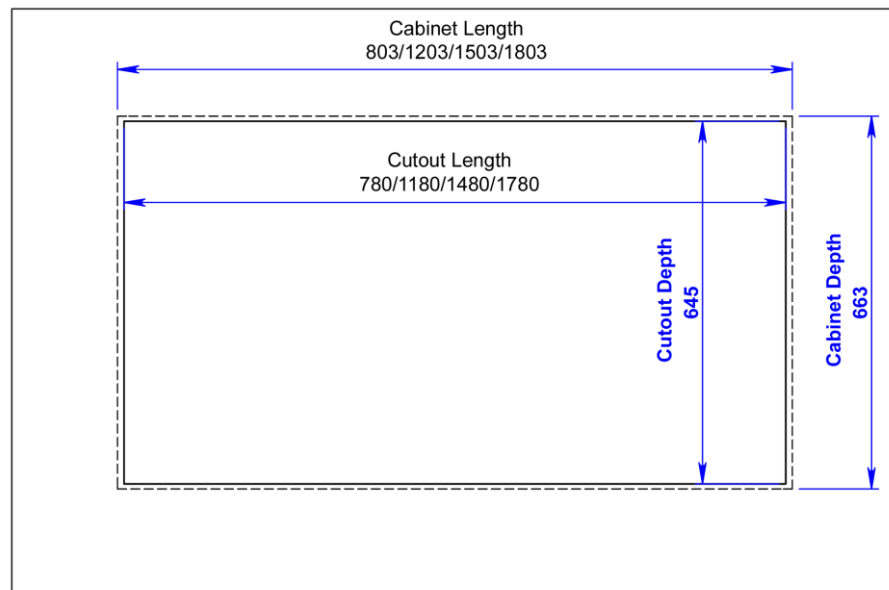

Continued on next page

Bench Cut-outs cont.

REFRIGERATED CABINETS - MECHANICAL DRAWINGS

On Bench Mounting

The following diagram shows the size and location of the holes, required for the cabinets to sit on the bench.

The holes are always in the same location, with reference to the back, right hand corner of all cabinets.

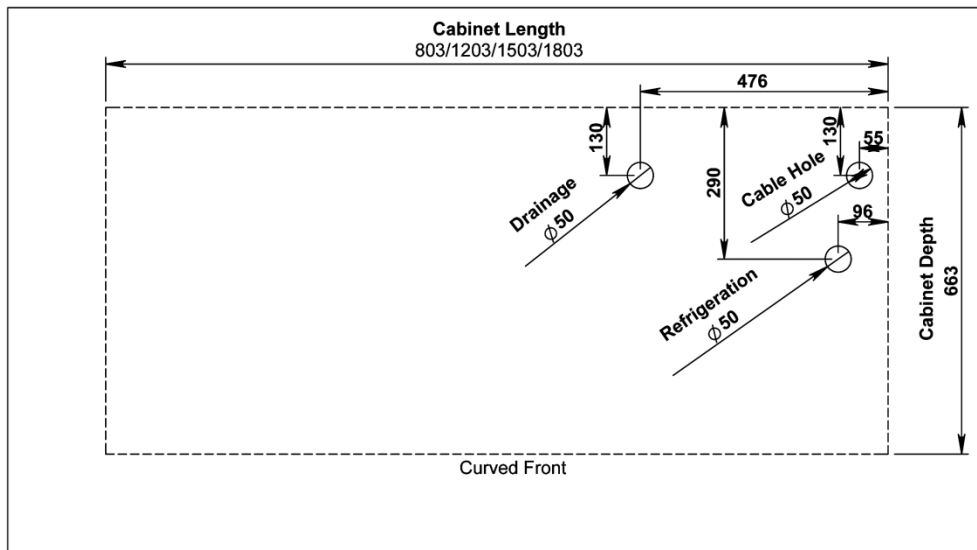

On Bench Mounting with Integral Condenser

The following diagrams show the aperture dimensions, which will allow the three sizes of cabinet to sit on the bench.

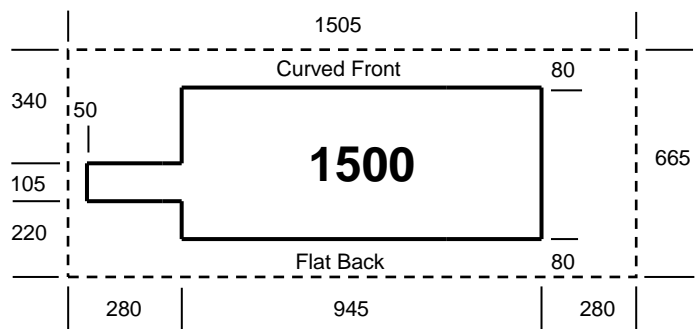
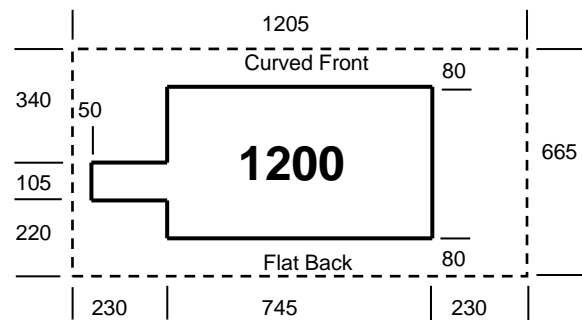
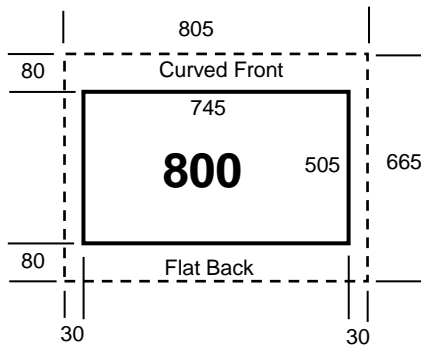

All dimensions are in millimetres.

Diagrams are not to scale.

Ventilation

REFRIGERATED CABINETS - MECHANICAL DRAWINGS

Under-bench Enclosure As detailed under Location in the Installation section, adequate ventilation must be provided for the refrigeration condenser unit.

If the back of the bench is to be enclosed, suitable ventilation grills and baffles must be fitted into the joinery panels.

Air Flow Baffles To prevent warm air re-circulating inside the enclosure, baffles must be constructed to separate the inlet and exit air.

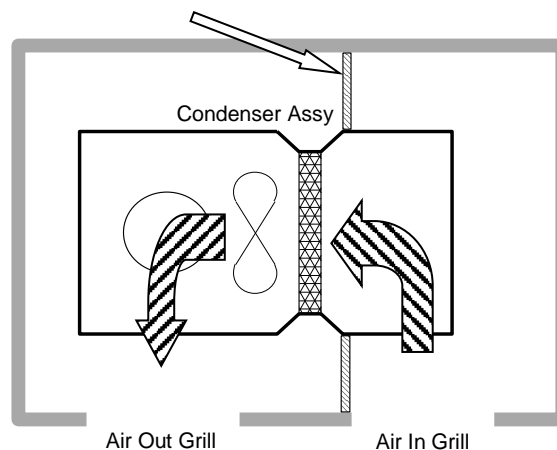

Grill Dimensions

Each grill, in and out, should have a minimum open area of 730 cm².

A suitable sheet metal grill may be made by punching a pattern of 49 rectangular holes, each 40mm x 40mm. The holes may be spaced by 5mm.

Suitable grills can be supplied by FPG, as an optional extra.

It is not recommended to use louver panels, as they would have to be very large to achieve the required open area, and be more prone to becoming blocked with fluff and dust.

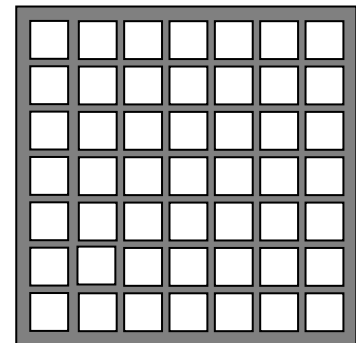



For full contact details please visit the Contacts page on **FPGWORLD.COM** or email us at support@fpgworld.com
In line with policy to continually develop and improve its products, Future Products Group reserves the right to change specifications and design without notice.

AUSTRALIA

E ausales@fpgworld.com
T 1800 813 745

INDONESIA

E idsales@fpgworld.com
T +62 811 152 7288

CHINA | ASIA

E asales@fpgworld.com
T +86 21 3351 3390

UAE

E info@sparrow-international.com
T +971 4 340 4795

EUROPE

E eusales@fpgworld.com
T +31 6 5253 4769

NEW ZEALAND

E nzsales@fpgworld.com
T 0800 367 374

INDIA

E insales@fpgworld.com
T +91 98 1020 5058

UNITED KINGDOM

E uksales@fpgworld.com
T 0808 234 7922

