



FPGWORLD.COM

# INLINE

## 4000 SERIES 1200 IN-COUNTER/CURVED HEATED

RANGE	INLINE 4000 SERIES	
TEMPERATURE	HEATED	
MODEL	IN-4H12-CU-FF-IC	IN-4H12-CU-SD-IC
FRONT	CURVED/ FIXED FRONT	CURVED/ SLIDING DOORS
INSTALLATION	IN-COUNTER	
HEIGHT	993mm	
WIDTH	1203mm	
DEPTH	774mm	

TEMPERATURE RANGE	+30°C - +90°C
RECOMMENDED CORE PRODUCT TEMPERATURE	+65°C - +80°C
ENVIRONMENTAL TEST CONDITIONS	22°C / 65% RH

## FEATURES

- High energy efficiency: **1.10 kWh per hour (average)**
- Cabinet operating temperature range **+30°C - +90°C**  
Recommended core product temperature **+65°C - +80°C**
- Smart display with toughened safety glass encased in brushed stainless steel frame

### Fixed Front or Sliding Doors Heated Display

- Three tiltable, height-adjustable stainless steel wire rack shelves are full cabinet width to support maximum display capacity
- 25,000 hour LED lighting system at 2758 lumens per metre in cabinet top and shelves
- Unique shelf mounted ticket strip front and rear: 30mm
- Extrusion at the top of the cabinet - front only - is fitted with a stainless steel panel that can be replaced with a branded insert

### Operational Excellence

- Sliding doors (staff side) and fixed front or sliding doors options (customer side)
- Constructed from stainless and mild steel with toughened safety glass and double-glazed end panels for maximum energy efficiency, climate control and durability
- Low-wattage, high-density element provides even temperature distribution
- Designed to be installed into joinery



Showing : Inline 4000 Series heated 1200mm curved in-counter with fixed front

## OPTIONS & ACCESSORIES

Contact a [FPG Sales Representative](#) for our full range, including:

- Shelf trays: Toughened safety glass or mild steel  
Colour and woodprint options available for steel shelf trays
- Stainless steel product trays with sides
- Stainless steel pie chutes
- Additional shelf
- Branded decals/insert
- Rear door or end glass mirror application
- Forward-facing controls
- Custom joinery solution



Please contact FPG to discuss your requirements for meeting country-specific standards.

FPGWORLD.COM

### HEATED DATA

MODEL	TEMPERATURE RANGE	RECOMMENDED CORE PRODUCT TEMPERATURE	ENVIRONMENTAL TEST CONDITIONS	HEATING
IN-4H12-CU-XX-IC	+30°C - +90°C	+65°C - +80°C	22°C / 65% RH	Low-wattage, high-density element

### ELECTRICAL DATA

MODEL	VOLTAGE	PHASE	CURRENT	E24H (kWh)	kWh per hour (average)	IP RATING	MAINS		LED LIGHTING		
							CONNECTION	CONNECTION PLUG <sup>1</sup>	HOURS	LUMENS per metre	COLOUR
IN-4H12-CU-XX-IC	220-240 V	Single	7.2 A	26.40	1.10	IP 20	3 metre, 3 core cable	10 amp, 3 pin plug	25,000	2758 per metre	Natural

<sup>1</sup>Please advise country to change plug specification.

### CAPACITY, ACCESS & CONSTRUCTION

MODEL	DISPLAY AREA	LEVELS	ACCESS FRONT	ACCESS REAR	CHASSIS CONSTRUCTION
IN-4H12-CU-FF-IC	1.2 m <sup>2</sup>	3 Shelves	Fixed front	Sliding doors	Stainless 304 and mild steel
IN-4H12-CU-SD-IC	1.2 m <sup>2</sup>	3 Shelves	Sliding doors	Sliding doors	Stainless 304 and mild steel

### DIMENSIONS

MODEL	H x W x D mm (Uncrated)	MASS (Uncrated)
IN-4H12-CU-XX-IC	993 x 1203 x 774	140 kg

Crated weights and dimensions vary. Please contact us for information on your shipment.

#### Installation note:

Model cutout dimensions: IN-4H12-CU-XX-IC models require 1180 x 760mm benchtop cutout (see product manual for installation guide).

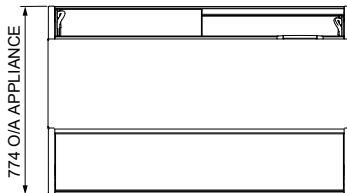

PLAN VIEW

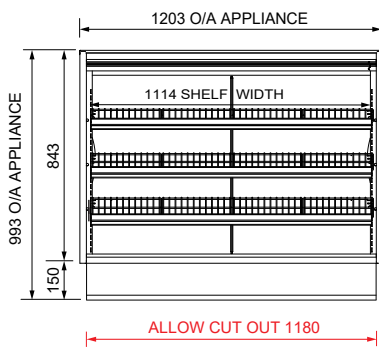

FRONT ELEVATION

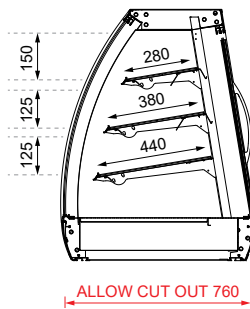

SECTION VIEW

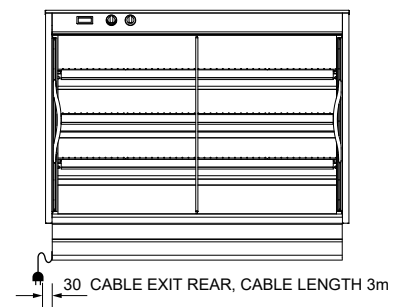

REAR ELEVATION

More information including technical data and installation guidelines is available from the Product Manual published on our website.

In line with our policy to continually develop, improve and support our products, Future Products Group Ltd reserves the right to change specifications and design without notice.

Have a question? Please email us at [sales@fpgworld.com](mailto:sales@fpgworld.com) or visit [www.fpgworld.com](http://www.fpgworld.com) for full contact details for your region.

